

# STATE HIGHWAY 300 BRIDGE H-11-U OVER LAKE FORK CREEK, COLORADO

Bridge H-11-U is located in Lake County on State Highway 300 ML where the highway crosses Lake Fork Creek. Figure 1 shows Bridge H-11-U over Lake Fork Creek.

Hydrau-Tech, Inc. began the POA study of Bridge H-11-U by collecting information on the site and structure in question, including hydrologic characteristics of the site, GIS information and original bridge construction plans. Using these parameters, regional regression equations result in a 500-year flood discharge of 860 cfs (cubic feet per second). After completing a survey of the reach upstream and downstream of the structure and sediment size analysis, a HEC-RAS hydraulic model was developed. This model was used to estimate the hydraulic conditions during the 500-year flow including: discharge distributions, velocity distributions, and water surface profiles. Figure 2 shows the water surface profile produced by the HEC-RAS hydraulic model. Figure 3 shows the reach geometry plot produced by HEC-RAS.

Using the results from hydraulic modeling, theoretical scour estimates were calculated with FHWA's HEC-18 scour equations. Updated AutoCAD drawings were produced with adjusted datum elevations and theoretical scour lines in order to determine the stability of the structure under the scour conditions created by flooding. Figure 4 shows a completed theoretical scour plot using AutoCAD showing foundation elevations and potential scour.



Figure 1. Bridge H-11-U over Lake Fork Creek

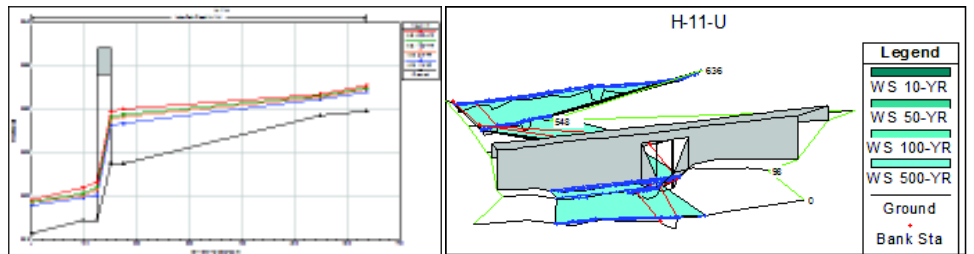

Figure 2 (Left). Water surface profile showing the 10, 50, 100 and 500-year flows  
Figure 3 (Right). 3D Plot of the reach around structure H-11-U

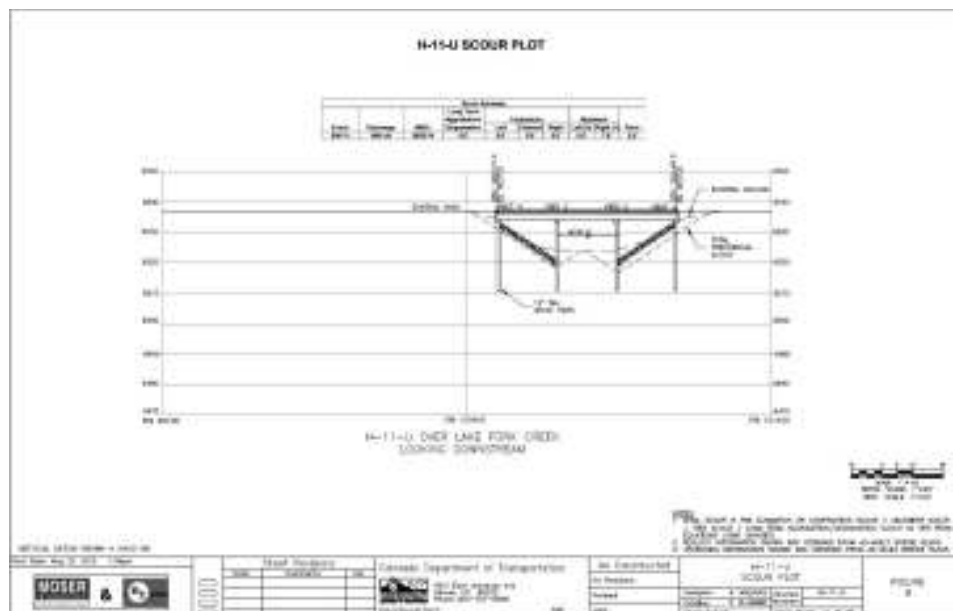

Figure 4. Scour plot generated in AutoCAD showing bridge geometry, foundation elevations, sediment boring hole results and theoretical scour

Based on the theoretical scour and the current site conditions such as foundation depths and existing structure protection, countermeasures were designed by Hydraul-Tech, Inc. Riprap was chosen as the preferred hydraulic scour countermeasure. Pier riprap and abutment riprap sizing were selected by using FHWA's equations. Based on the theoretical velocities, riprap with a median grain size diameter of 1.0 feet was used to design the abutment and pier protection. Using the guidelines in HEC-23 for riprap protection design,

Hydraul-Tech, Inc. developed preliminary riprap countermeasures at each of the critical locations on the bridge (abutments and piers). Figure 5 shows an aerial image of structure H-11-U with the recommended scour countermeasure. Figure 6 shows a cross-sectional view of the structure with the recommended scour countermeasures and appropriate geometry. As a part of analysis, various cost estimates for alternative countermeasures were complete for comparison.

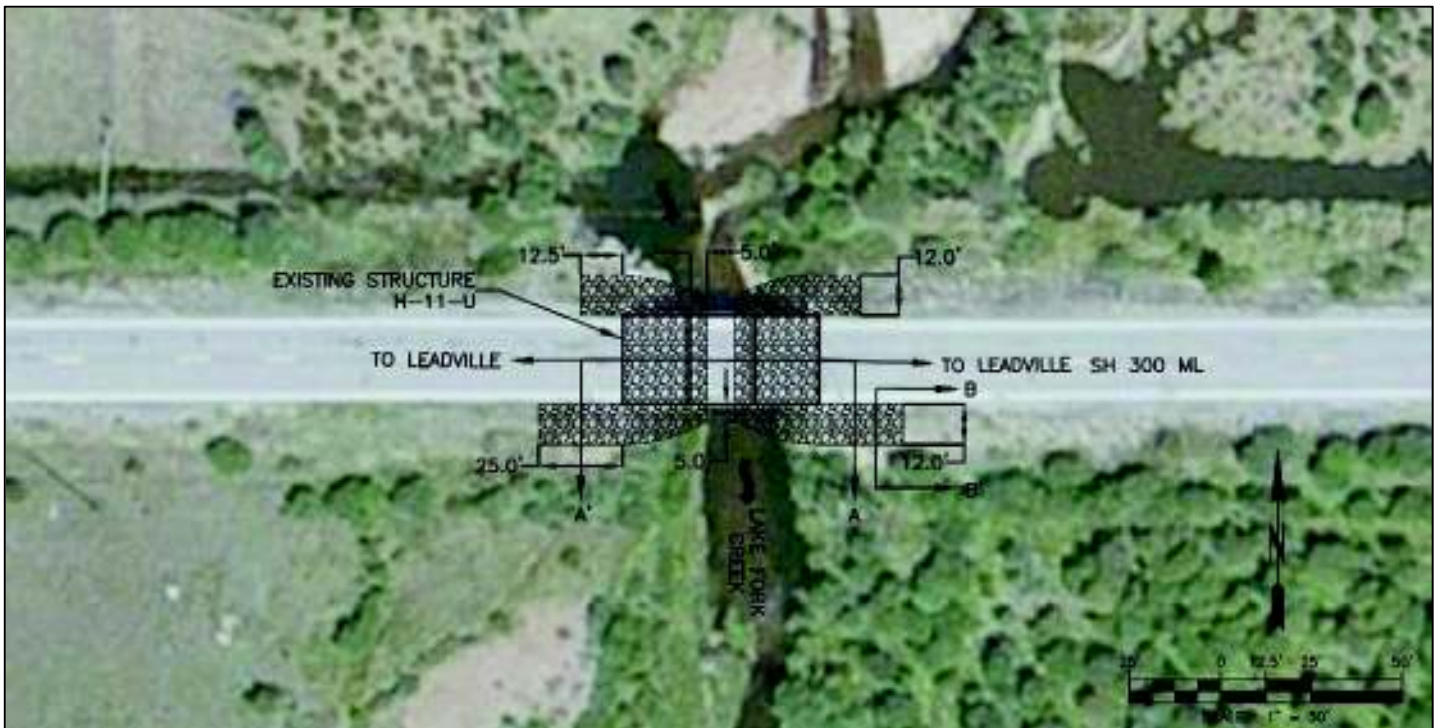

Figure 5. Plan view of Bridge H-11-U with recommended hydraulic scour countermeasure locations

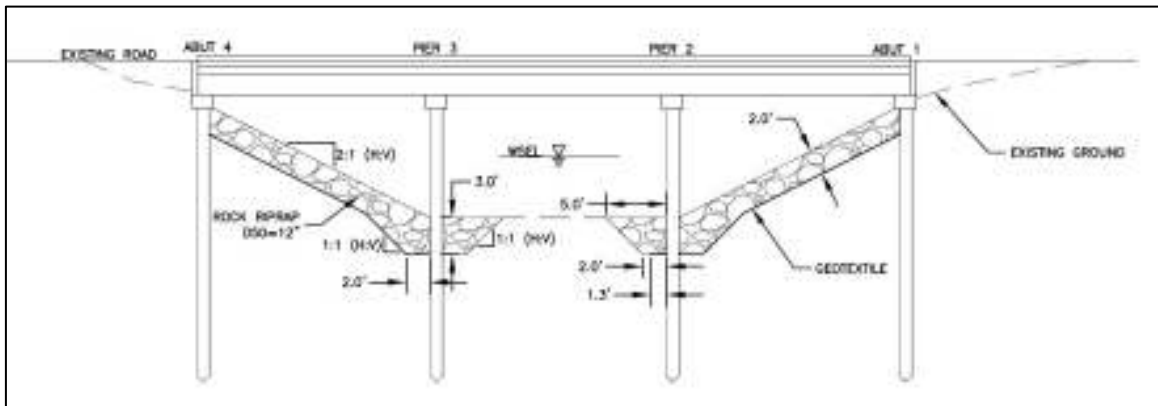

Figure 6. Cross-sectional view of Bridge H-11-U with recommended hydraulic scour countermeasures